**Operating mode:**

By operating the hand lever on the upper part (1), the crossway bolt is displaced radially. The crossway bolt is pressed into the bore of the lower part (2).

Advantages:

Withstands high loads with low dead weight

Intuitive operation

Can be released and closed with one handle

High repeatability +/- 0.02 mm

Holds up to 5,000 changing cycles

Optional connection of a power coupling SEK for electrical ducts

Interface according to DIN EN ISO 9409-1

With 6 integrated pneumatic ducts

Technical specifications		SHW063-P
Basic material		Al. anod.
External diameter x height [mm]		63 x 32
Pitch circle diameter [mm]		50
Repeatability +/- [mm]		0,02
Tension Fz [N]		700
Compression -Fz [kN]		80
Torsion Mz [Nm]		80
Bend Mx, My [Nm]		70
Mass [kg]	upper part	0,25
	lower part	0,1
Recommended load [kg] *		12
Locking force VF [N]		4 - 50
Locking stroke VH [mm]		0 - 1
Pneumatic ducts	connection	3 x M5 & 3 x D=4
	max. pressure p [bar]	6

* This guideline applies to the following assumptions:
Acceleration: 10 m/s², gravity distance: 150 mm, double safety

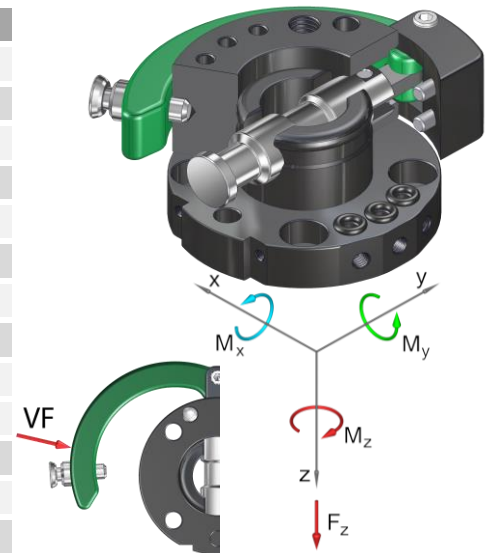

Pos.	Description
1	Upper part
2	Crossway bolt
3	Hand lever
4	Holder
5	Strap pin
6	Spring locking pin
7	Guiding screw
8	Index pin
9	Cylinder bolt BL
10	Cylinder bolt QB
11	Shim ring
12	Lower part
13	O-ring

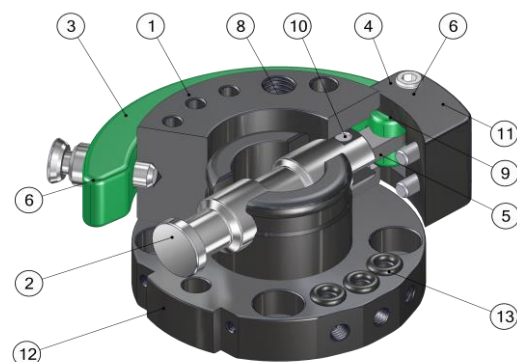
**Thrust lever change system Ø63...**

G-SHW063-2OEP	drilled acc. to ISO, upper part, E-Mount, 6 pneumatic ducts, Al, anodized
G-SHW063-2UEP	drilled acc. to ISO, lower part, E-Mount, 6 pneumatic ducts, Al, anodized