

Dear customer,

Congratulations!

You have chosen the best product we know how to make with our 30 years of experience and passion for precision.

Please follow the instructions in this manual to avoid mistakes and save time.

In case you need further information or you have further requests we will be glad to be at your disposal.

With best regards,

Your GRIP GmbH

GRIP GmbH Handhabungstechnik
Alter Hellweg 70
44379 Dortmund, Germany

Tel. +49 231 96450 01

info@grip-gmbh.com
www.grip-gmbh.com

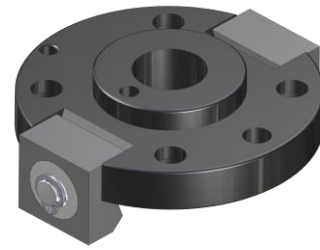

SWA Connector

	Contents	Page
1	Operation	2
2	Safety	3
	2.1 Symbol	3
	2.2 Intended use	3
	2.3 Environmental and operating conditions	3
	2.4 Safety indication	3
3	Warranty	3
4	Scope of delivery	4
5	Technical data	4
6	Assembly	4
7	Maintenance and care	5
	7.1 Disassembly	5
	7.2 Torque specification	5
8	Parts list	5
	8.1 Spare and wear parts	5
9	Exploded view	6
10	EC-Declaration of incorporation	7

1 Operation

To operate the SWA Connector, use an allen key . To open, turn the allen key counter-clockwise till the stop. This opens the flanges and releases the lower assembly. The upper and lower assembly can now be pulled apart.

To assemble, ensure the flanges are open, when joining the upper and lower assembly. Turn the allen key clockwise till stop to close the flanges. Due to the wedge profile, this locks the upper and lower assemblies together. Be sure to use the predetermined tightening torque to ensure proper locking.

Image 1

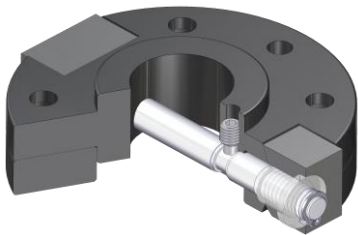
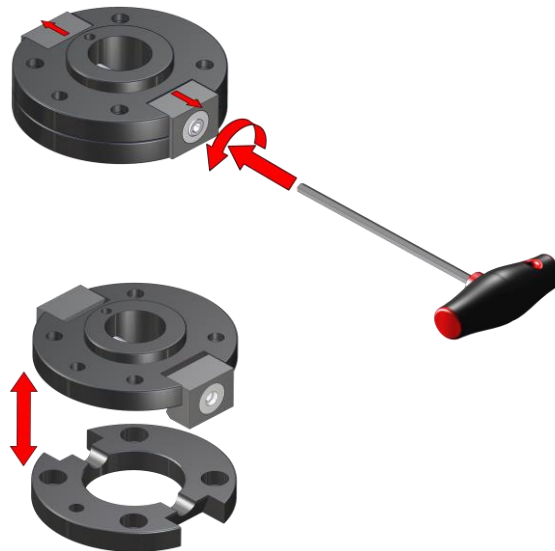

Image 2



NOTICE! Do not use tools that overload the axis!

Do not use any tools, that increase the torque effect of the lever. Make sure that the allen key is in good working condition and fully inserted into the axis.

Recommended torque values:

SWA050: 16 Nm

SWA063: 16 Nm

SWA080: 16 Nm

SWA100: 24 Nm

SWA125: 36 Nm

SWA160: 40 Nm



NOTICE!

In dynamic applications, it is important that the axis is correctly torqued with the recommended torque values!

Note, even with proper torquing a loosening of the axis can not be ruled out.

2 Safety

2.1 Symbol



This symbol indicates possible hazards to persons or the SWA Connector.

2.2 Intended use

The SWA Connector has been designed as an interface between handling device and tool (e.g. gripper). Furthermore, the SWA can also be used in special solutions, automation and also as a general mechanical standard interface. The unit may only be used in the context of its technical specifications. The system is intended for the installation in a machine. The requirements of the applicable instructions must be considered and adhered to.

2.3 Environmental and operating conditions

Use this unit only in dry and splash-proof environments at room temperature as well as within the application parameters defined in the technical specifications. If this is not the case, warranty cannot be accepted. Exceptions are units designed especially for the respective conditions.

2.4 Safety indication

Dangers may arise from the unit, if:

- the product is not installed or inserted properly,
- the system is not used for its intended purpose,
- the safety and installation notes are not observed.

Everyone who is responsible for assembly, commissioning and maintenance must read and understand the complete operating instructions. Improper use, which affects the function and operational safety of the SWA Connector, is prohibited.

CAUTION! Never open the connector when the load is suspended!



In order to prevent damage to the connector as well as injuries to the operator, the lower assembly or the tool must be secured by hand or other devices before opening the change system. Otherwise there is a risk that irreparable damages to the tool or injury to the operator are caused by the unit falling down.



NOTICE!

The unit may only be operated if the machine in which the unit is installed complies with the relevant provisions of the machinery directive 2006-42-EC.



NOTICE!

Conduct assembly, maintenance and repair work only outside the hazardous areas or when the power supply is switched off.

3 Warranty

If the product is used as intended in 1-shift operation the warranty is valid for 24 months from the ex-works delivery date under observance the mandatory maintenance and lubrication intervals and the given operating conditions. Generally parts touching the work piece and wear parts are not part of the warranty. Wear parts are listed in chapter 8.1. The unit is considered to be defective if its basic function "Lock" is no longer functioning.

4 Scope of Delivery

- SWA as painted in Image 5 depending on the order number of the upper or lower assembly.

5 Technical Data

Behold technical data sheets: TD-SWA050-EN, TD-SWA063-EN, TD-SWA080-EN, TD-SWA100-EN, TD-SWA125-EN, TD-SWA160-EN

6 Assembly

The upper assembly of the SWA Connector is mounted on the robot flange, the manipulator or similar actuators. The upper assembly of the SWA is positioned centrally over the centering pin. The angular orientation is determined by a fitting bore. The lower assembly is mounted on grippers, measuring instruments or other tools. Again a centering should be generated. If the SWA Connector can not be installed due to space limitations, adapter flanges can be used. Use screws according to DIN 912 / ISO 4762 during mounting. The screw-in depth of the screws must be observed. We recommend the use of a "medium-tight" screw lock.

For the angular orientation there is a fitting bore for the sizes 050 to 080 available. For the sizes 100 to 160 there are two fitting bores on the flange surfaces. These are executed according to ISO 9409.

**CAUTION!**

Perform assembly work only when the power supply is switched off!

**CAUTION! Risk of pinching the fingers when closing the SWA**

When closing the connector ensure fingers are not between the upper and lower assembly.

Image 3

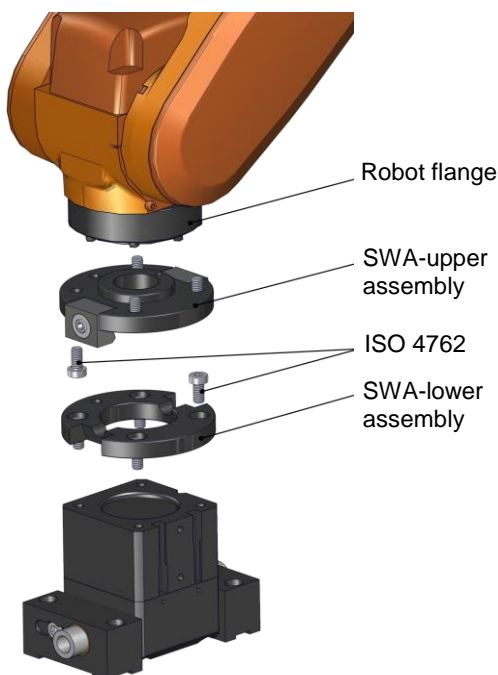

7 Maintenance and care

The SWA is virtually maintenance-free. Check the semi-cylindrical bolt in regular intervals for correct function. Keep the mating surface and the moving parts clean and lubricate them slightly. Spare parts and component parts of the SWA can be found on our homepage: www.grip-gmbh.com

7.1 Disassembly of the SWA

(Behold Image 4)

1. Disassemble the SWA.
2. Loosen the Setscrew (pos. 6).
3. Rotate the axis (pos.2) counter-clockwise until the flanges (pos.3) are released.
4. Loosen the Setscrew (pos. 5).
5. Remove the axis (pos. 2) from the upper assembly (pos. 1).
6. Clean all parts thoroughly. Inspect for wear and defects.
7. Lubricate all mating surfaces.

For assembly, reverse the order.

7.2 Torque specifications

M6 – 8,5 Nm; M8 – 20,6 Nm; M10 – 41 Nm; M12 – 71 Nm

8 Parts list

Pos.	Description	Quantity
1	Upper assembly	1
2	Axis	1
3	Flange	2
4	Screw nut	2
5	Setscrew	1
6	Locking ring	1
7	Lower assembly	1
7	Index pin	1

8.1 Spare and wear parts, depending on size

Pos.	Description	Order-No.
2	Axis	EG-SWA...-A

9 Exploded view

Image 4

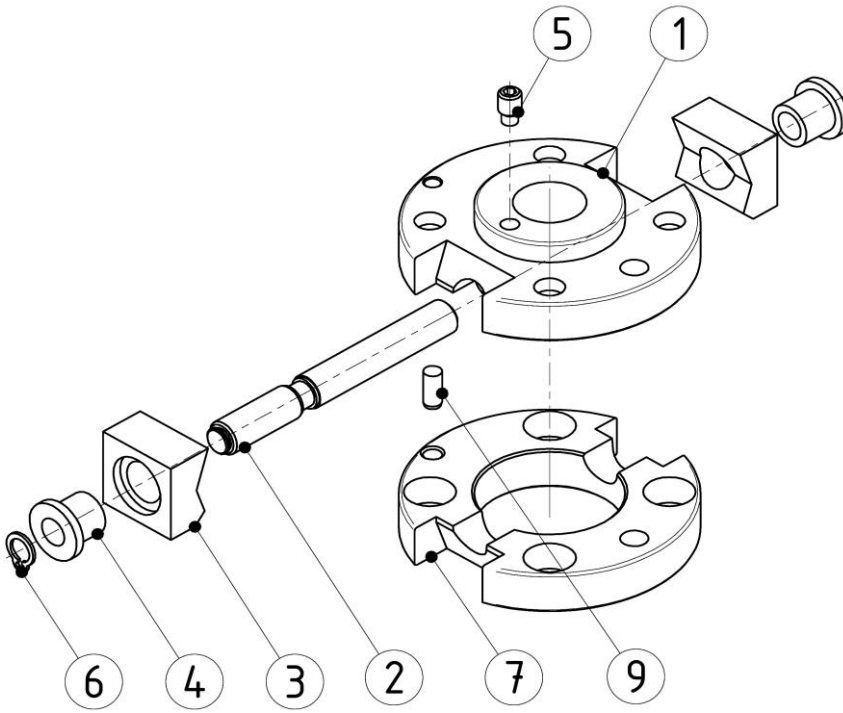
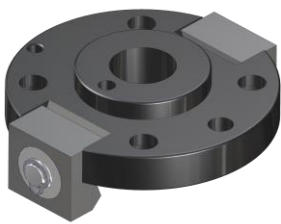

Image 5



Upper assembly



Lower assembly

10 EC – Declaration of incorporation

according to the Machinery Directive 2006/42/EG, annex II B

The producer / distributor GRIP GmbH Handhabungstechnik
Alter Hellweg 70
D-44379 Dortmund, Germany

hereby declares that the following products

Product designation: Quick change adapter (SWA)

Functional description: Systems for the manual and form-closed exchange of components such as grippers and tools on robots or receptacles

Type designation: G-SWA050 to 160

The provisions of the above-mentioned directives -including their effective amendments- comply with the time of the declaration.

He further states that the following essential requirements of the Machinery Directive 2006/42/EG were applied and observed:
annex I, numerics: 1.1.2; 1.1.3; 1.1.5; 1.3.2; 1.7.3; 1.7.4

He further states that the specific technical documentation has been drawn up in accordance with annex VII, Part B.

The following harmonized standard has been applied:

EN ISO 12100-1:2003 Safety of Machinery - Basic concepts, general principles for design - Part 1:
Basic terminology and methodology (ISO 12100-1:2003)

Safety of Machinery - Basic concepts, general principles for design - Part 2:
Technical principles (ISO 12100-2:2003)

In the case of reasoned requests, the specific documents shall be sent to the national authorities as follows: Post

The product mentioned above may only be put into operation if it has been established applicable that the unit, into which the above-mentioned product is to be incorporated, complies with the provisions of the Machinery Directive 2006/42 / EC.

Authorized representative: Dipl.-Ing. (FH) Hasan Canti

Location: Dortmund
Date: 14.09.2022



Dipl.-Ing. (FH) Hasan Canti
Executive Director